

# Σύστημα FFW70 Οδηγίες Συναρμολόγησης Φύλλου

## System FFW70 Panel Assembly Instructions

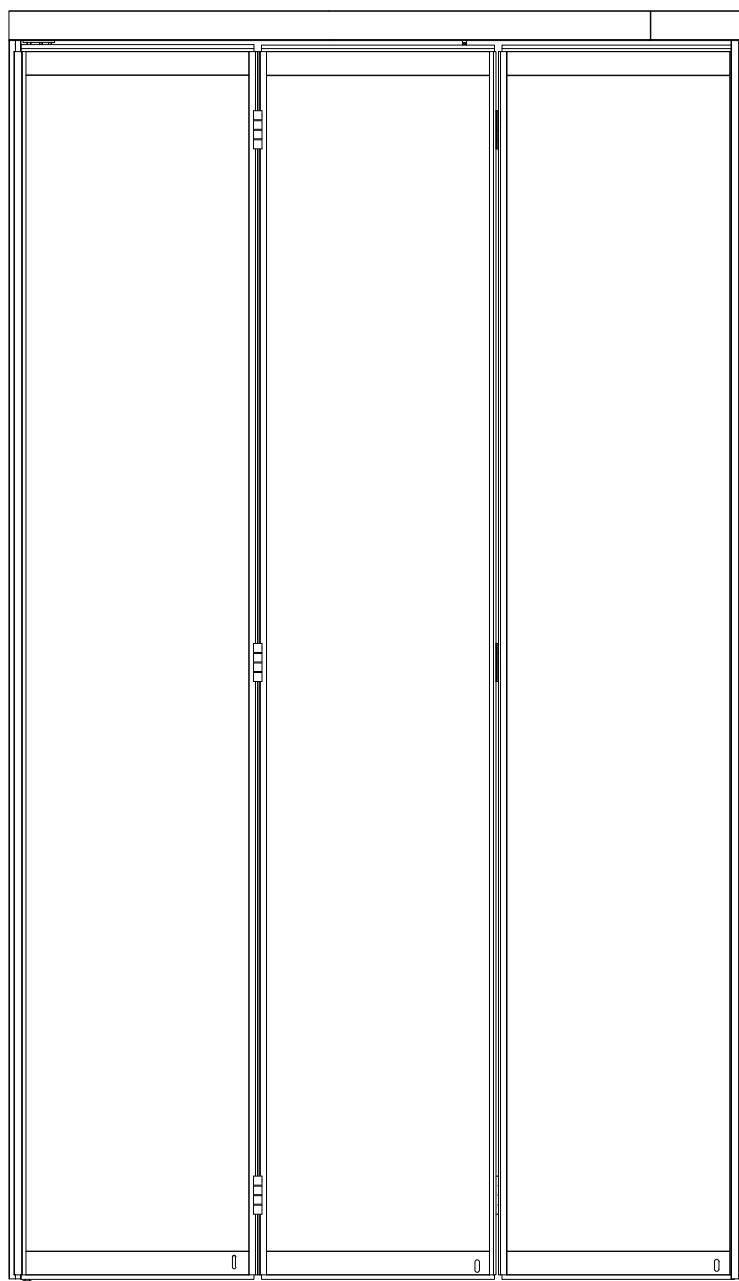

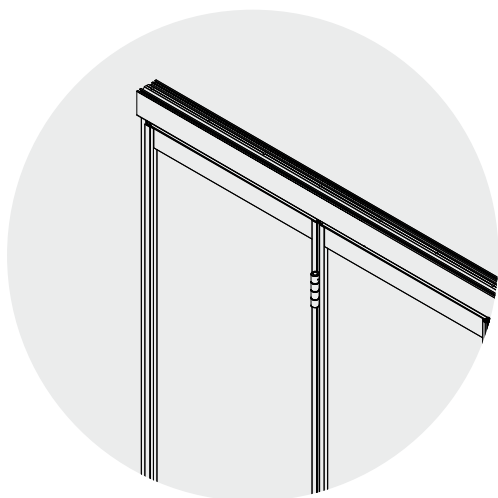
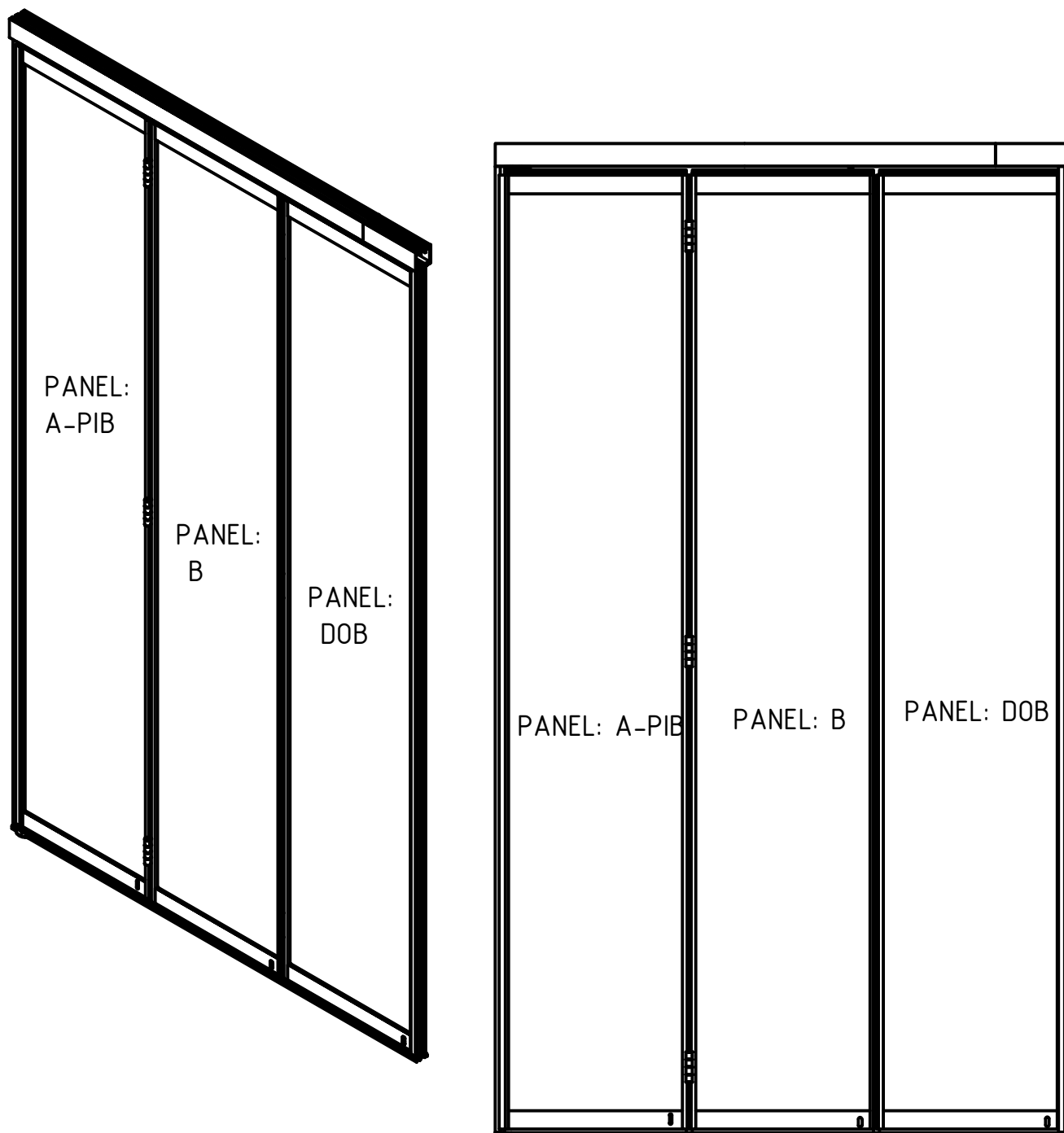

General view of the FFW70 system

FFW70 system  
Assembly instructions

Page: 2

Index / Contents

1. Tools required for the panel assembly.
2. List of parts provided by Ialonet S.A.
3. Panel assembly presentation.
4. Panel assembly instructions.
5. Appendix.

Part-1.

Tools required for the panel assembly:

Allen metric key set or use only the following three (3) allen keys:

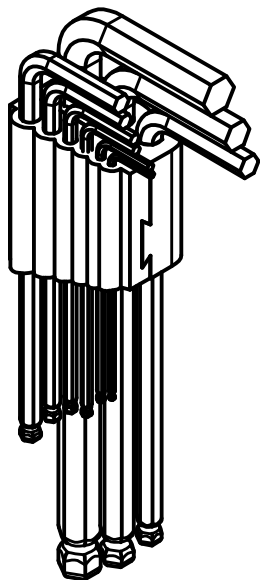

5mm allen key



3mm allen key



2.0mm allen key

Measuring tape

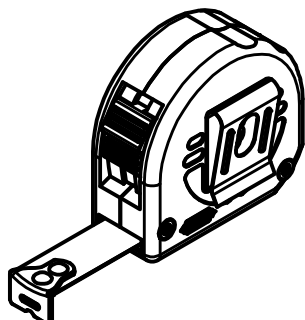

Suction cups

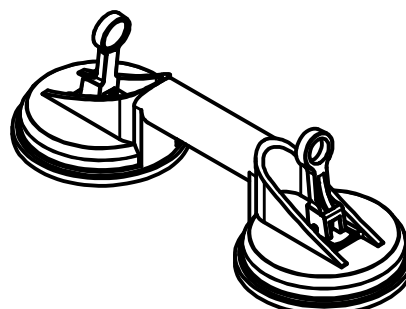

Saw horse with carpet or protected to prevent glass damage

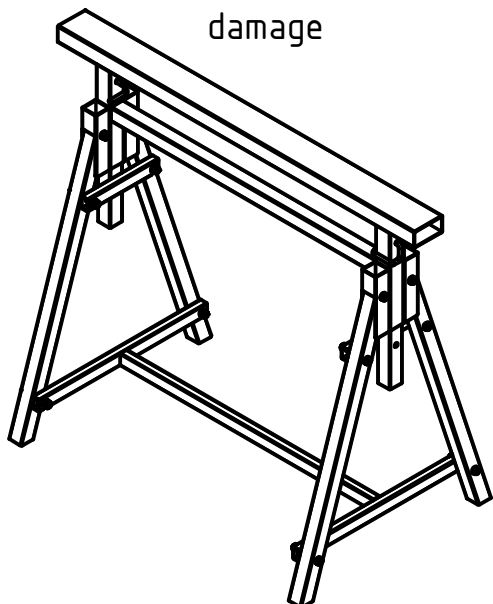

Silicone or RTV 408 gun

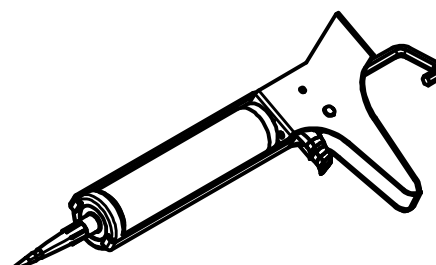

Part-1.

Tools required for the panel assembly:

Drills

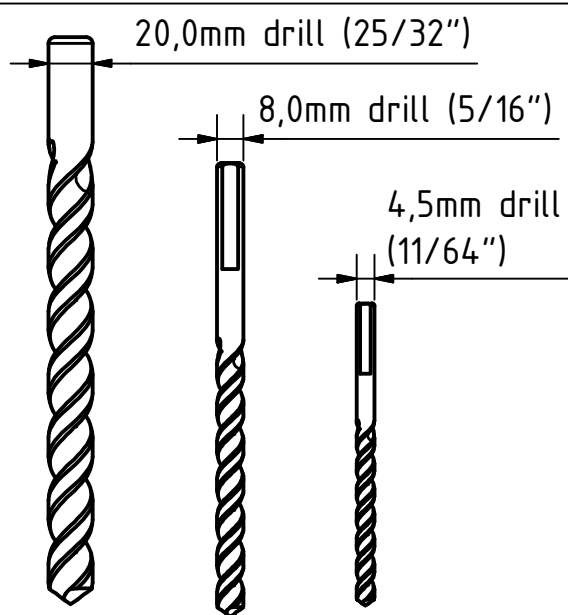

Portable drill machine  
(NOT impact drill)

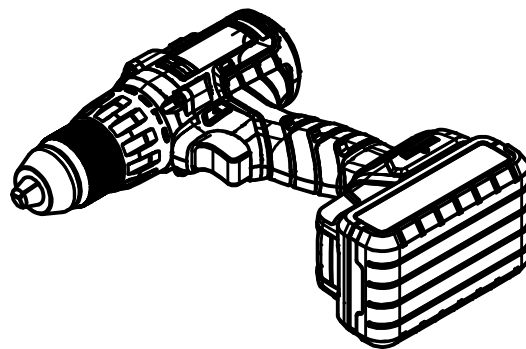

Screwdrivers  
Flat head & Philips

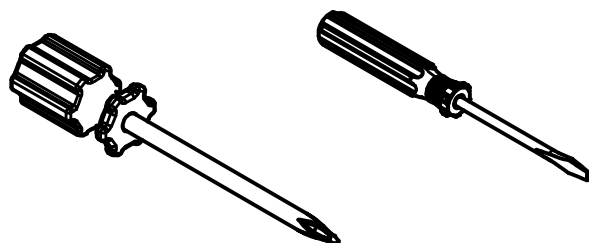

Knife

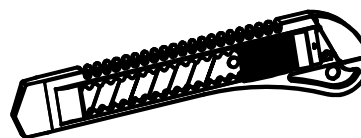

Rubber mallet

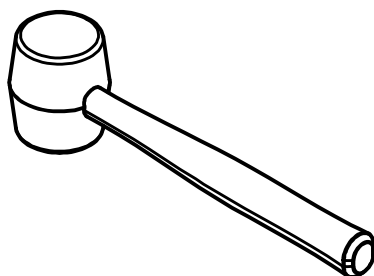

10mm Key

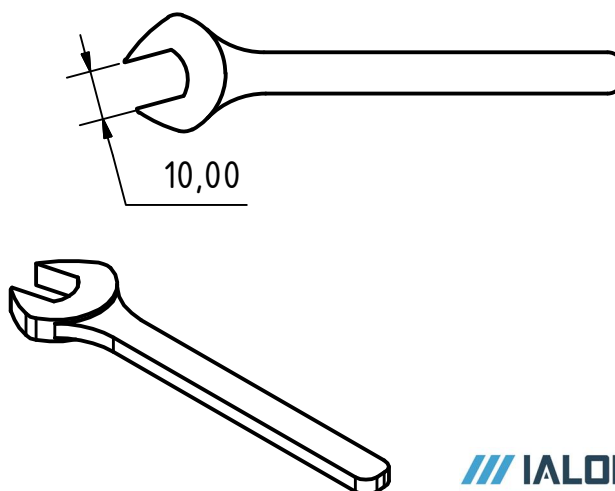

Parts provided by Ialonet P.C.:

Top track connectors  
(4mm stainless steel pins)

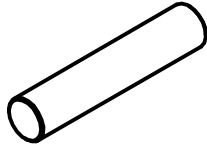

729.942 STOP

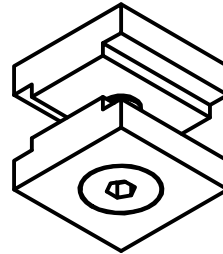

Top track connectors

729.657

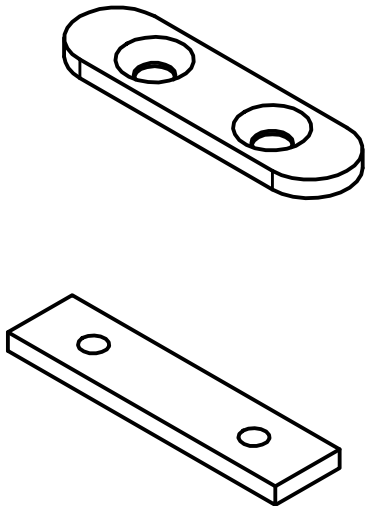

999.936 Lock casing  
(Dust-proof strike)

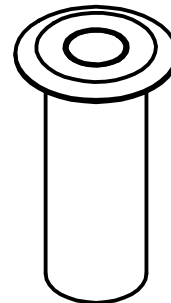

PLASTIC SPACER FOR GLASS

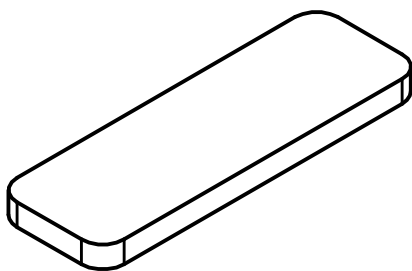

ST.STEEL SHEET METAL  
ROUND HEAD  
SCREWS 4.8x32

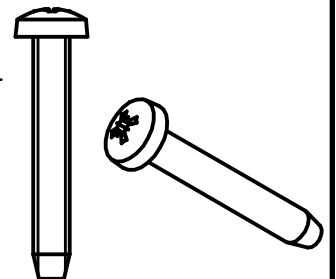

ST.STEEL SHEET METAL  
COUNTERSHUNK  
SCREWS 4.8x32



Parts provided by Ialonet P.C.:

Brush for guide profile  
and for panels

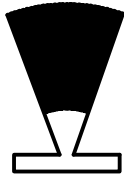

Rubber sealing profile  
and for panels

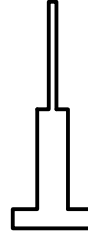

Rubber sealing profile  
and for panels



Rubber sealing profile  
and for the glass assembly  
into the panels

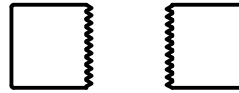

729.522

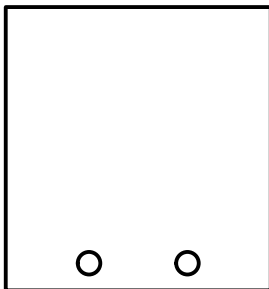

729.941 STOP

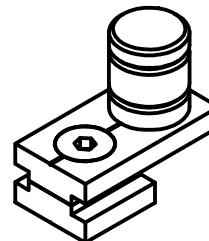

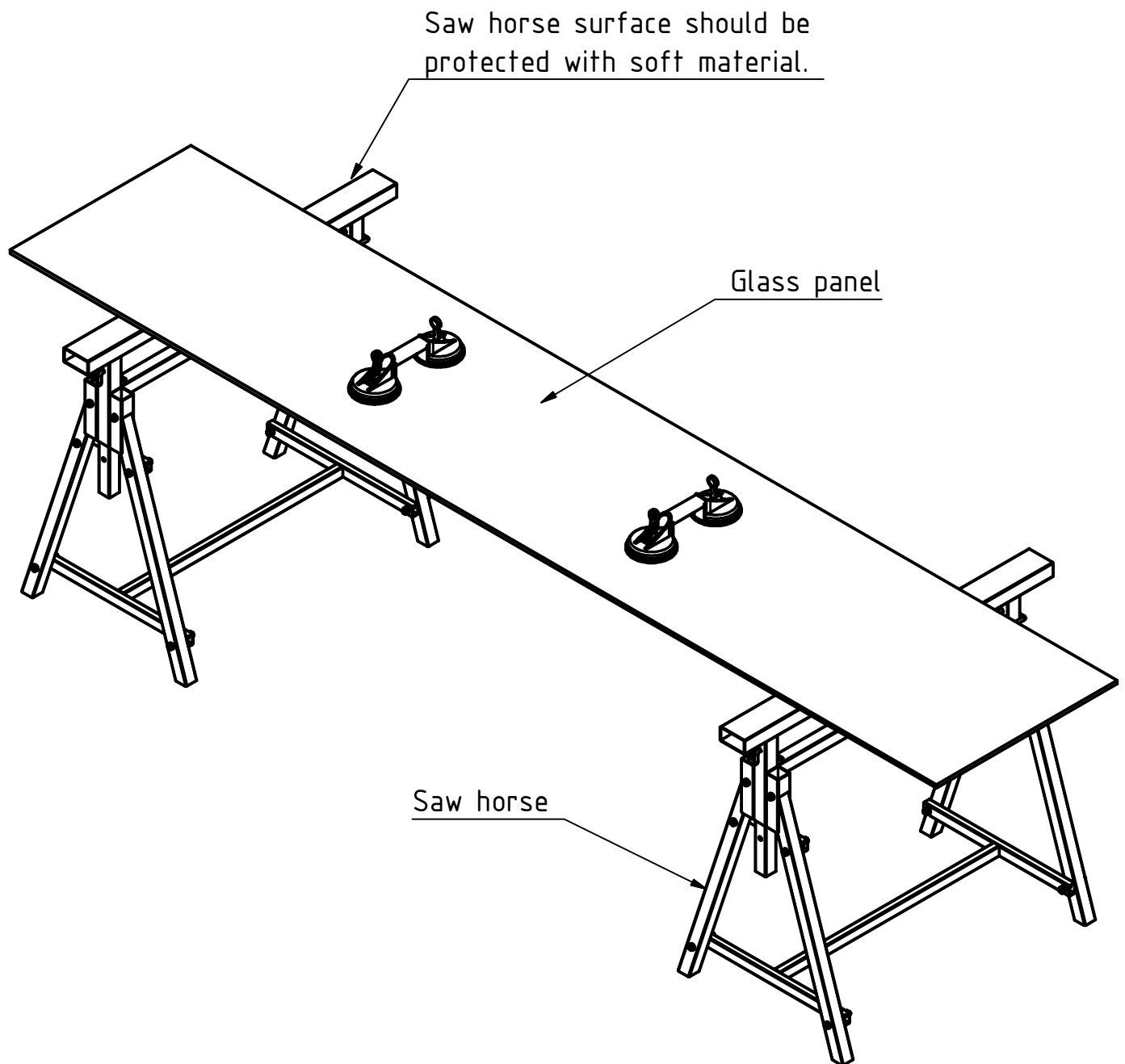
**STEP-1:**

Place the glass on the saw horses.  
Make the sure that the saw horse surface  
is protected with a soft material.



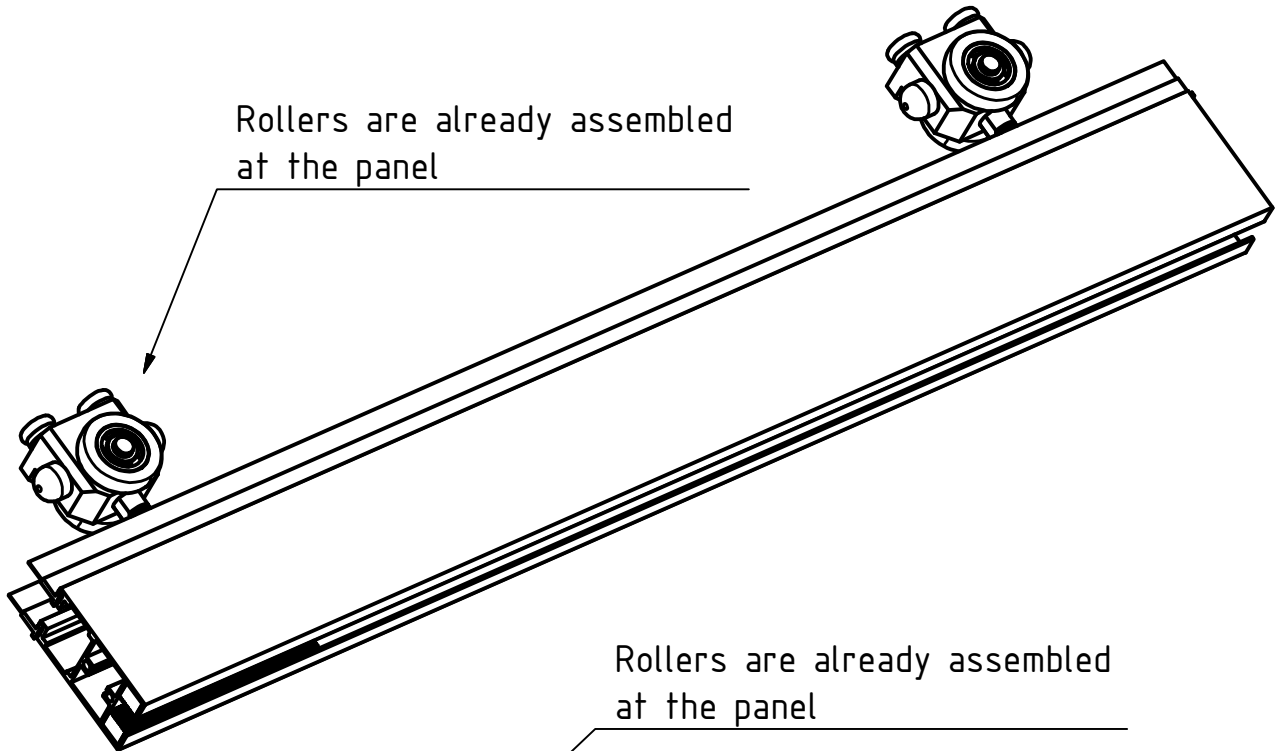

Rollers are already assembled at the panel

Rollers are already assembled at the panel

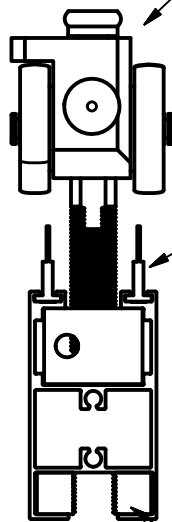

The rubber or the brush sealings are already assembled at the panel

Rubber for glass assembly is also assembled at the panel.

STEP-2:

Start from the upper panel.  
The panel is already assembled with either the rollers or the pivot if it is the opening door panel.

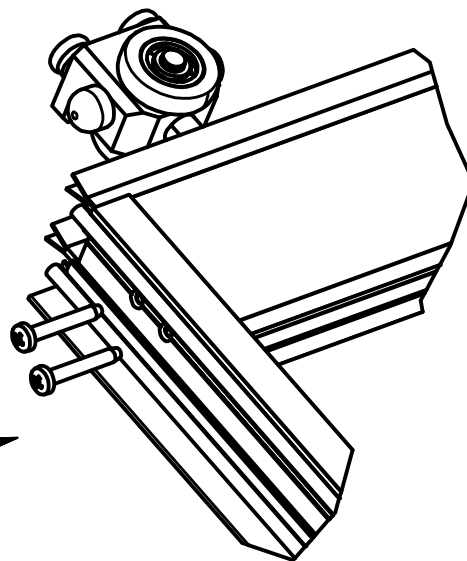
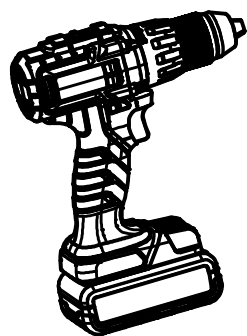
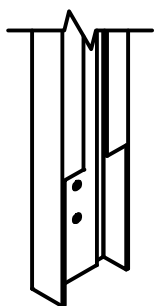
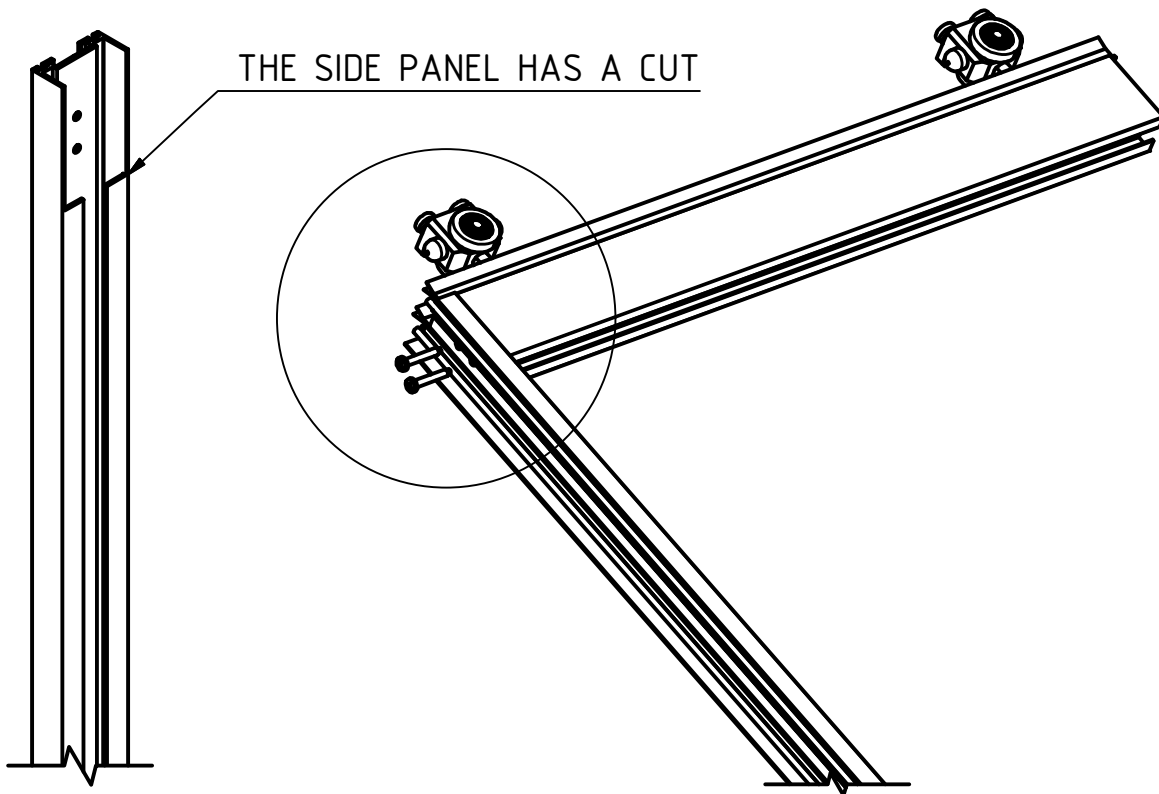

USE THE ST.STEEL  
SHEET METAL  
ROUND HEAD  
SCREWS 4.8x32  
(FOR ALL PANELS  
A-PIL, B & E).

STEP-2B:

Assembly the side panel with the upper panel.

After the panel assembly use  
a cutter to remove the remaining  
rubber sealings at the edge of the assembly

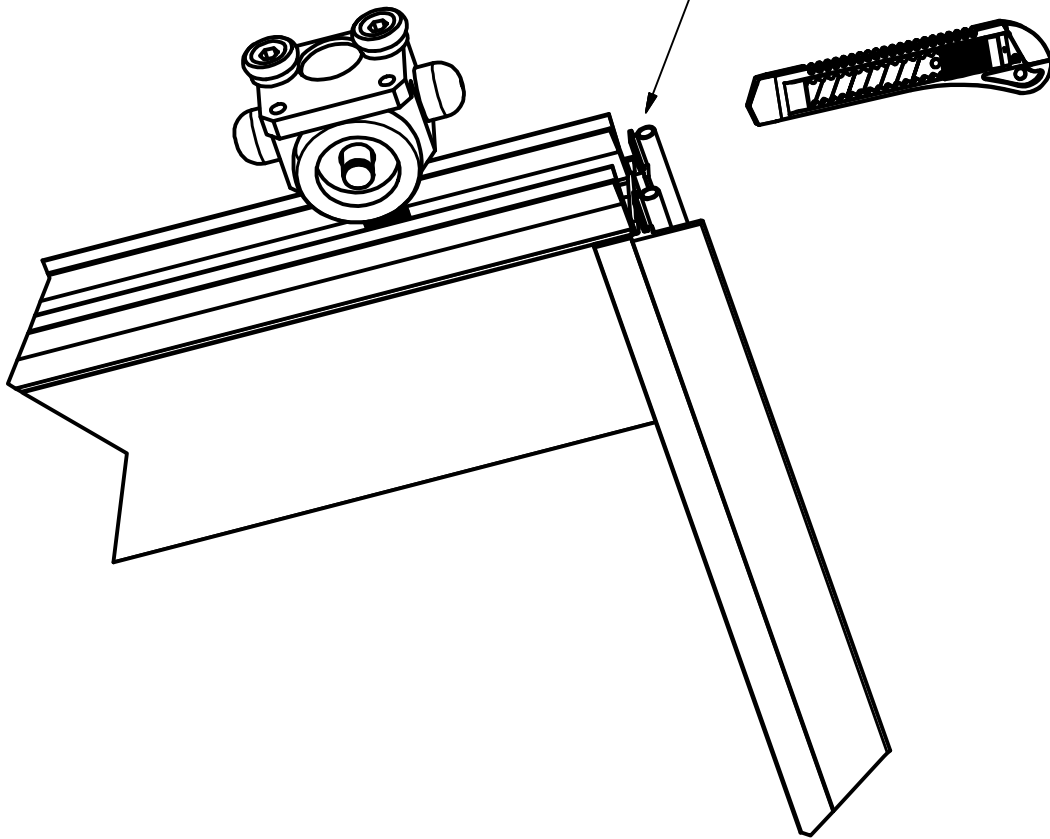

STEP-2C:  
Assembly the side panel with the upper panel.

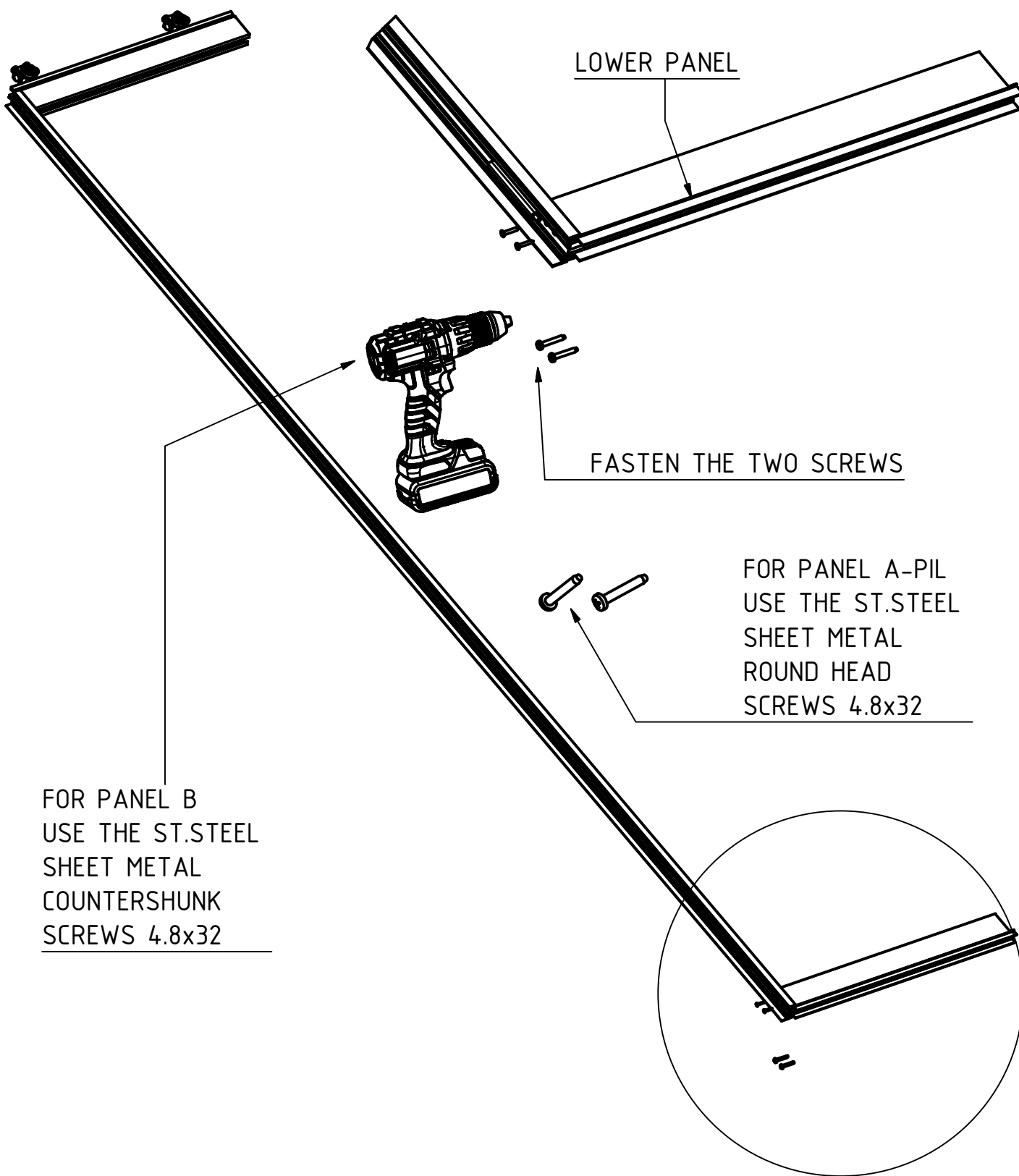

FASTEN THE TWO SCREWS

FOR PANEL A-PIL  
USE THE ST.STEEL  
SHEET METAL  
ROUND HEAD  
SCREWS 4.8x32

FOR PANEL B  
USE THE ST.STEEL  
SHEET METAL  
COUNTERSHUNK  
SCREWS 4.8x32

STEP-3:

Assembly the lower panel with the side panel.

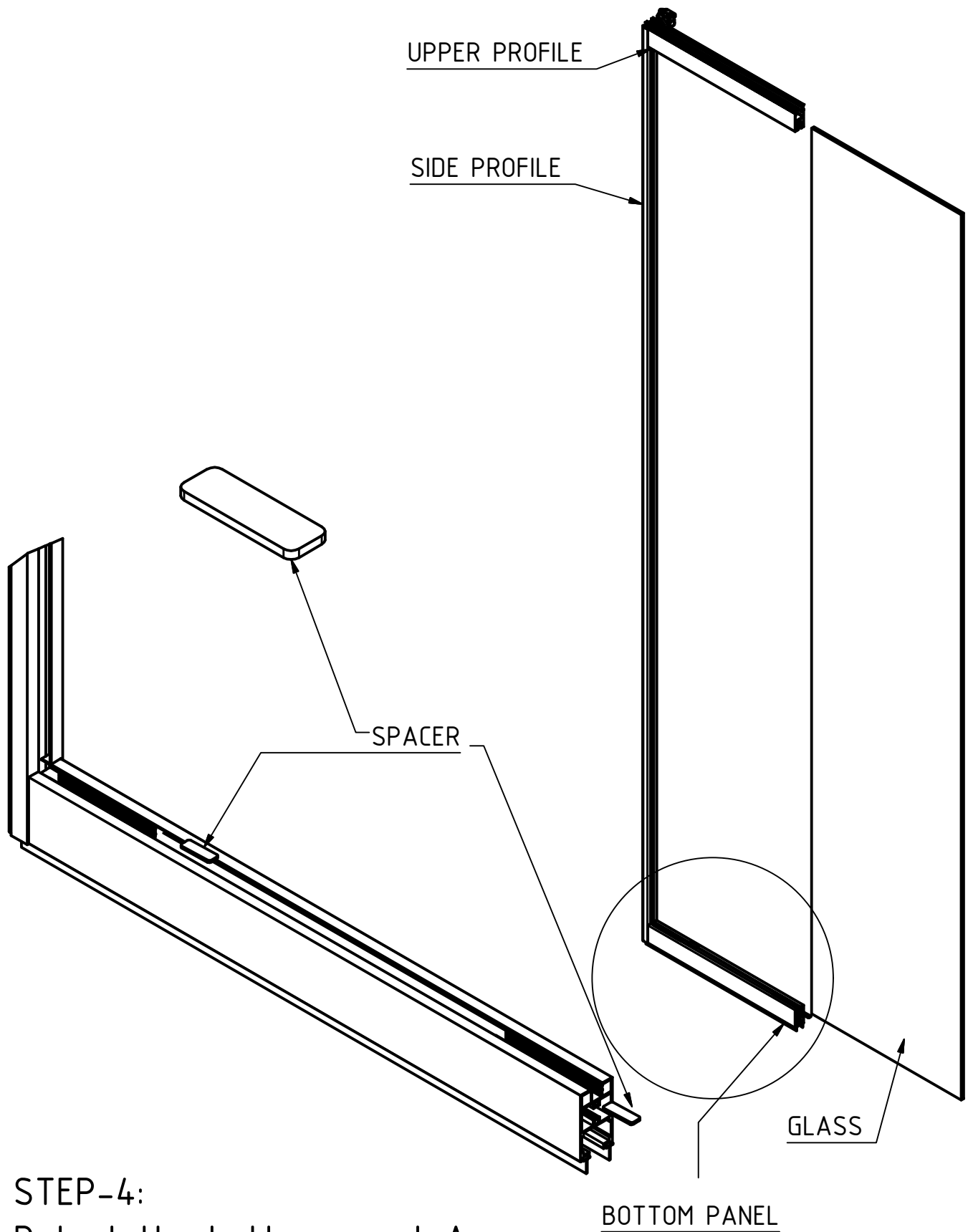
**STEP-4:**

Put at the bottom panel-A two (2) plastic spacers of 2mm thickness at the two edges of the panel so that the glass will not touch the aluminum profile.

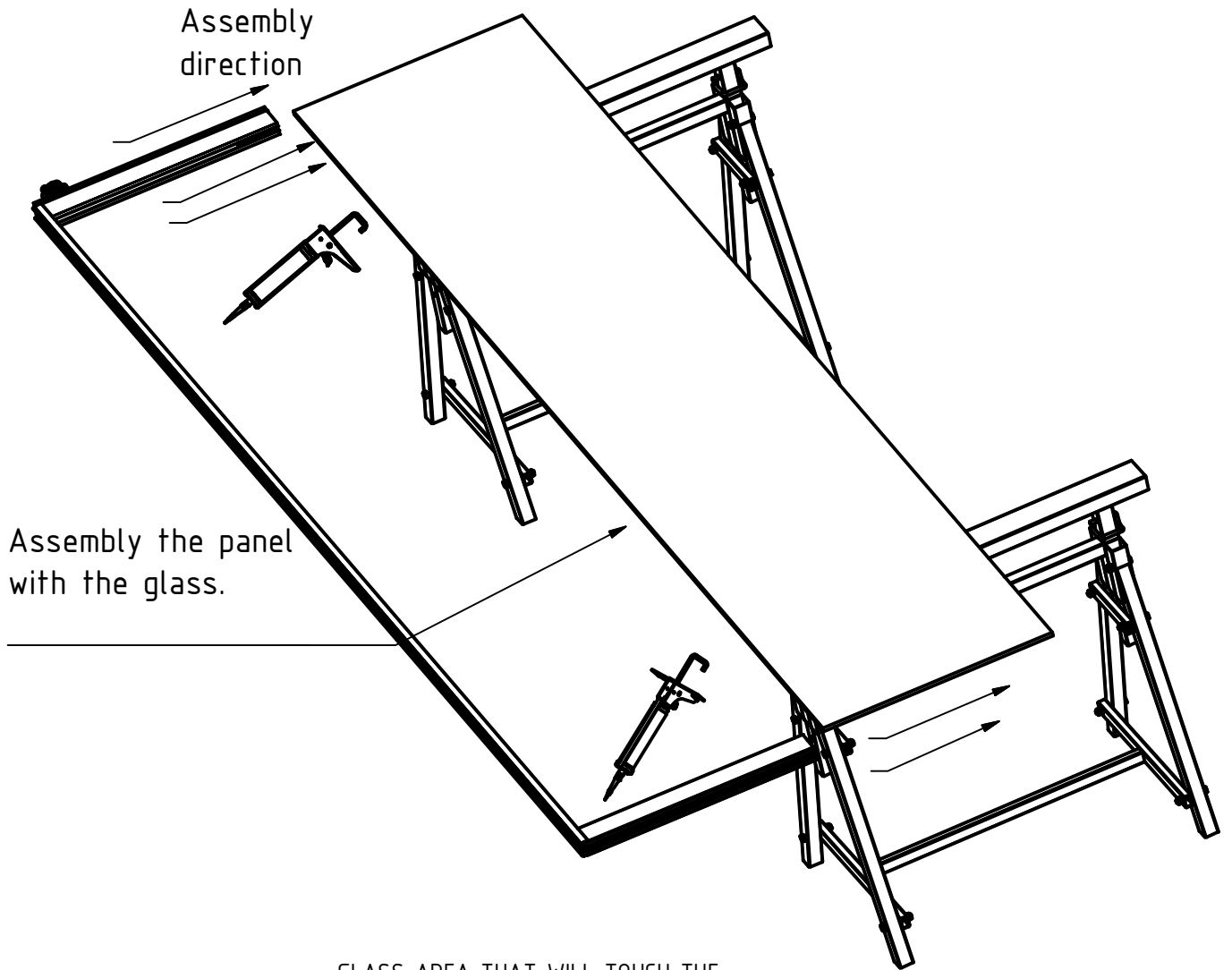

GLASS AREA THAT WILL TOUCH THE ALUMINUM PANEL

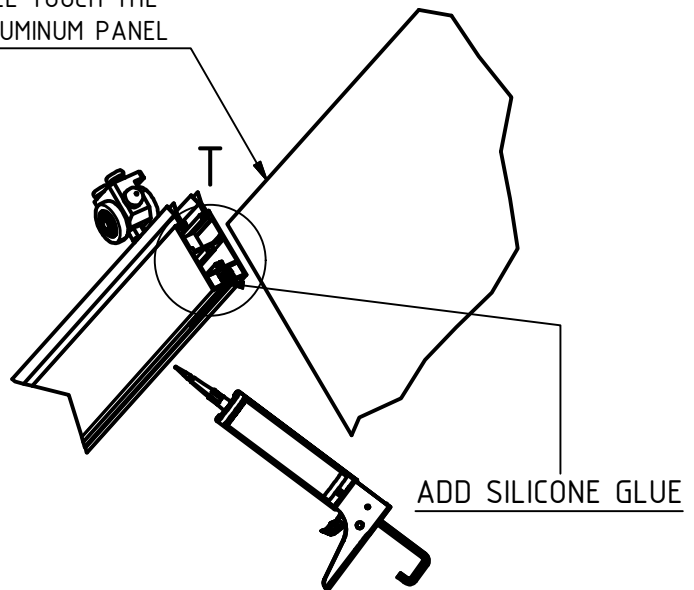
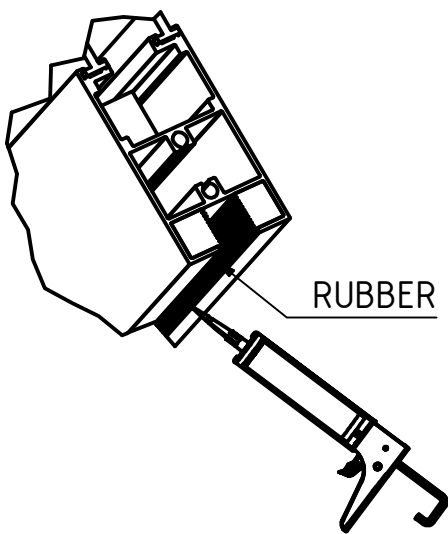

STEP-5:

Assembly the panels with the glass.  
Before the assembly silicone glue has to be applied to ALL of the panels.

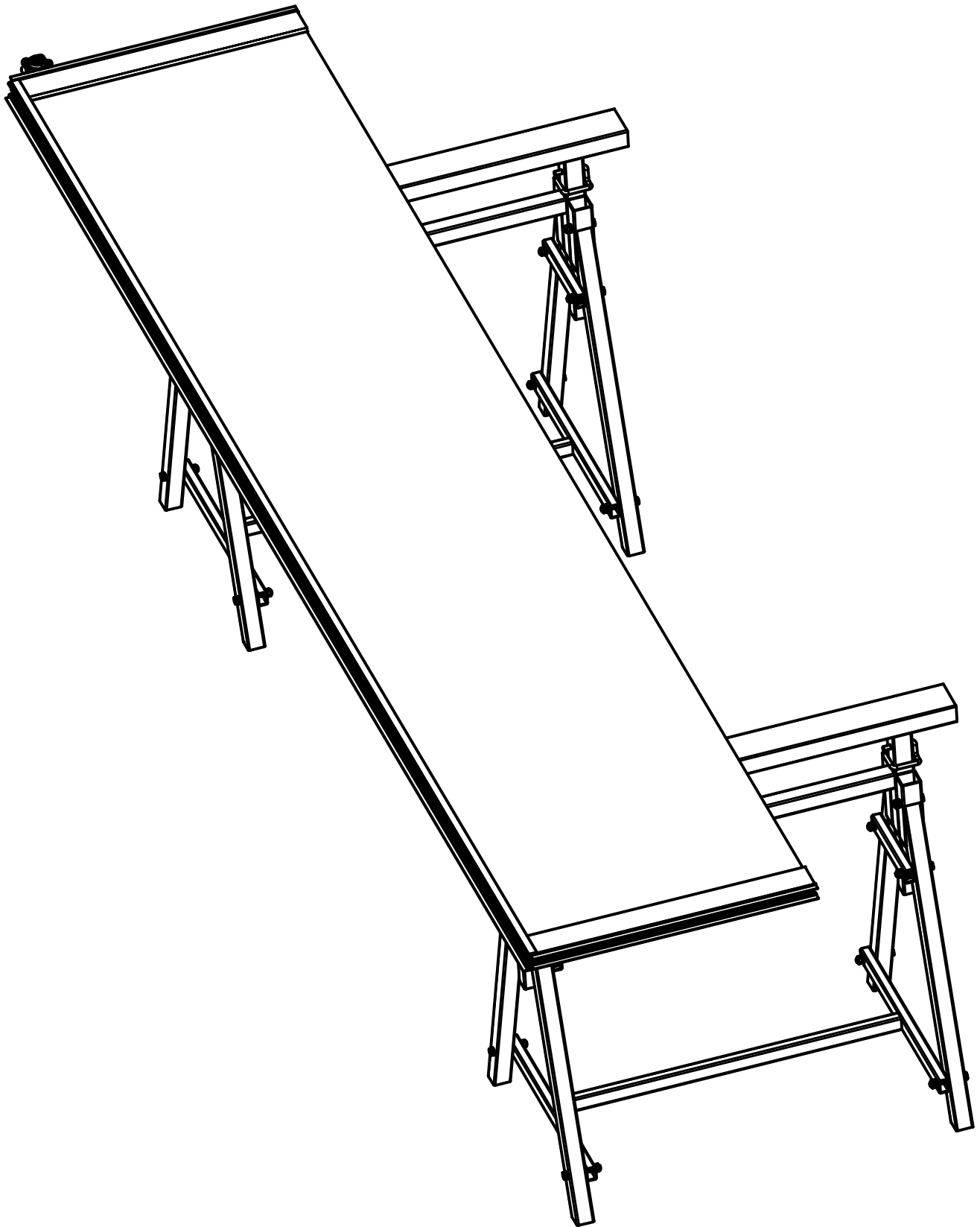

STEP-6:

3 Panels are assembled with the glass panel.

AT THE SECOND SIDE PANEL  
YOU MUST ASSEMBLY THE HINGE  
AND THE RUBBER BEFORE  
THE FINAL ASSEMBLY WITH  
THE GLASS.

SIDE PANEL FOR THE  
FIRST GLASS

SEALING RUBBER

SIDE PANEL FOR THE  
SECOND GLASS

STEP-6:  
PREPARATION FOR THE ASSEMBLY  
OF THE SECOND SIDE PANEL

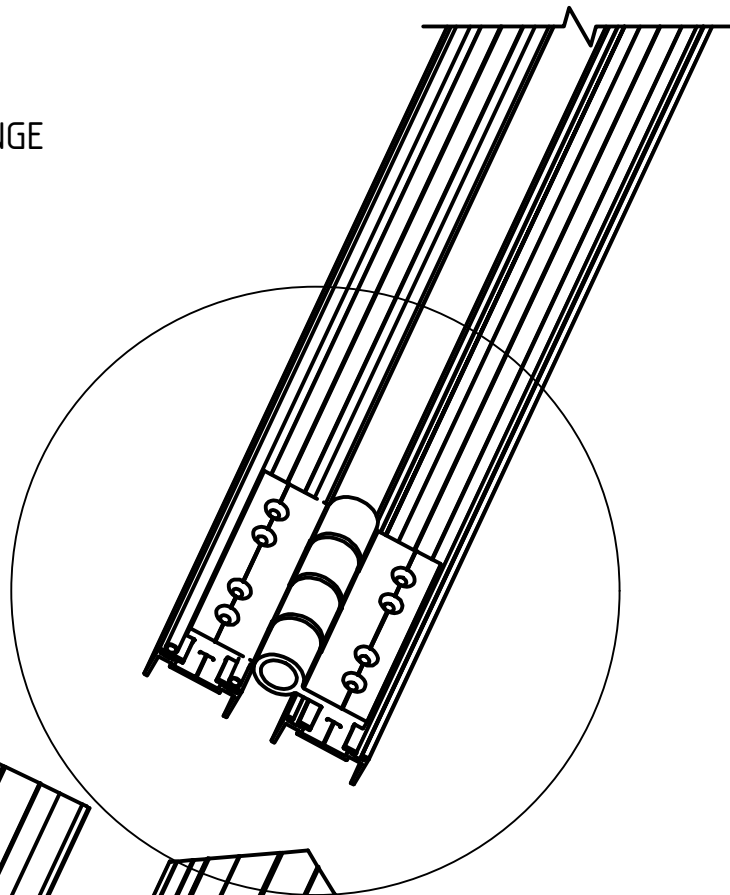



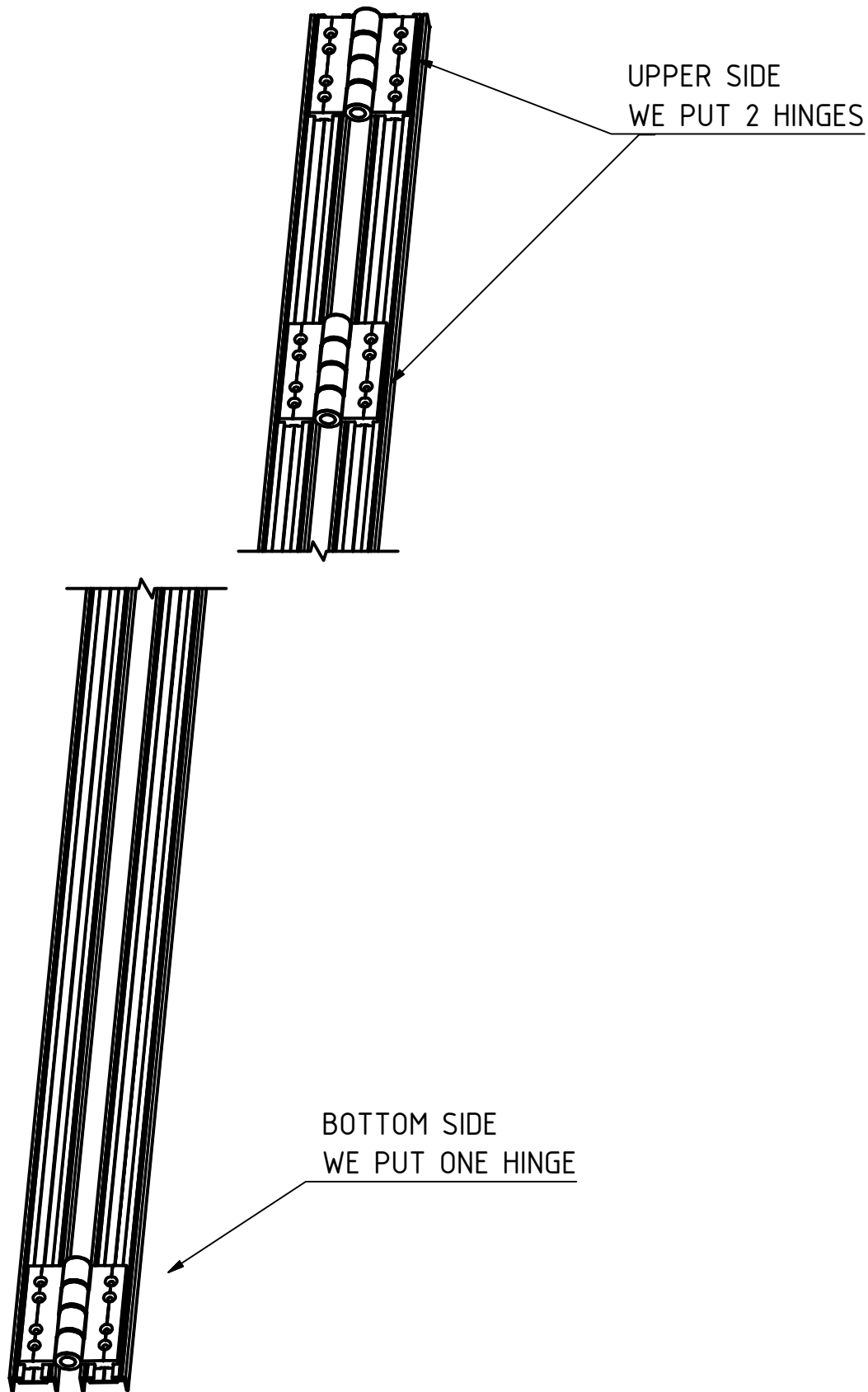

STEP-7:

Take (2) two side panels and (3) hinges.

*THE PANELS SHOULD NOT HAVE RUBBER SEALINGS IN THEM*

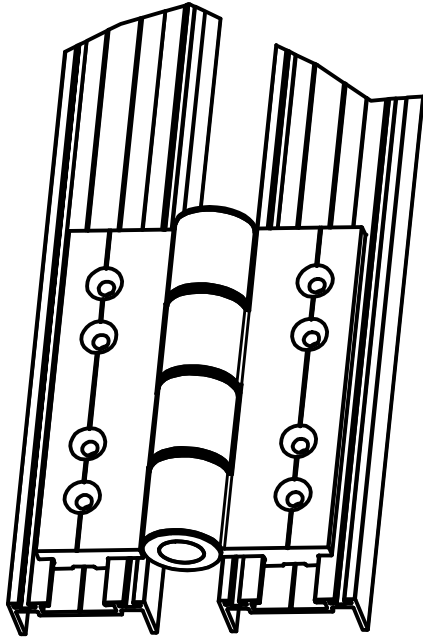

ASSEMBLY GEOMETRY

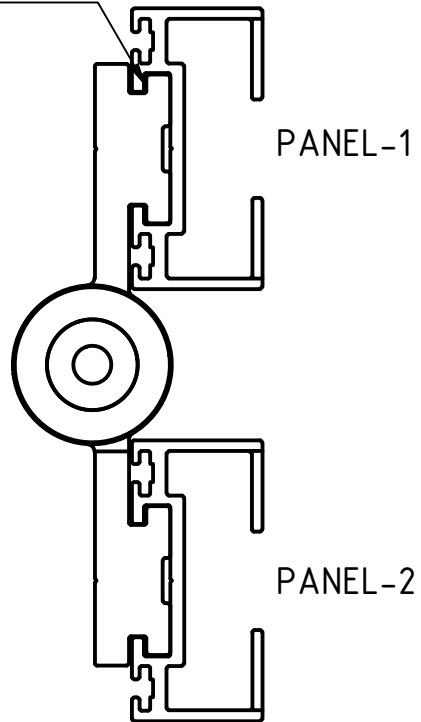

STEP-8:

Insert the hinges into the panels.

*THE PANELS SHOULD NOT HAVE RUBBER SEALINGS IN THEM*

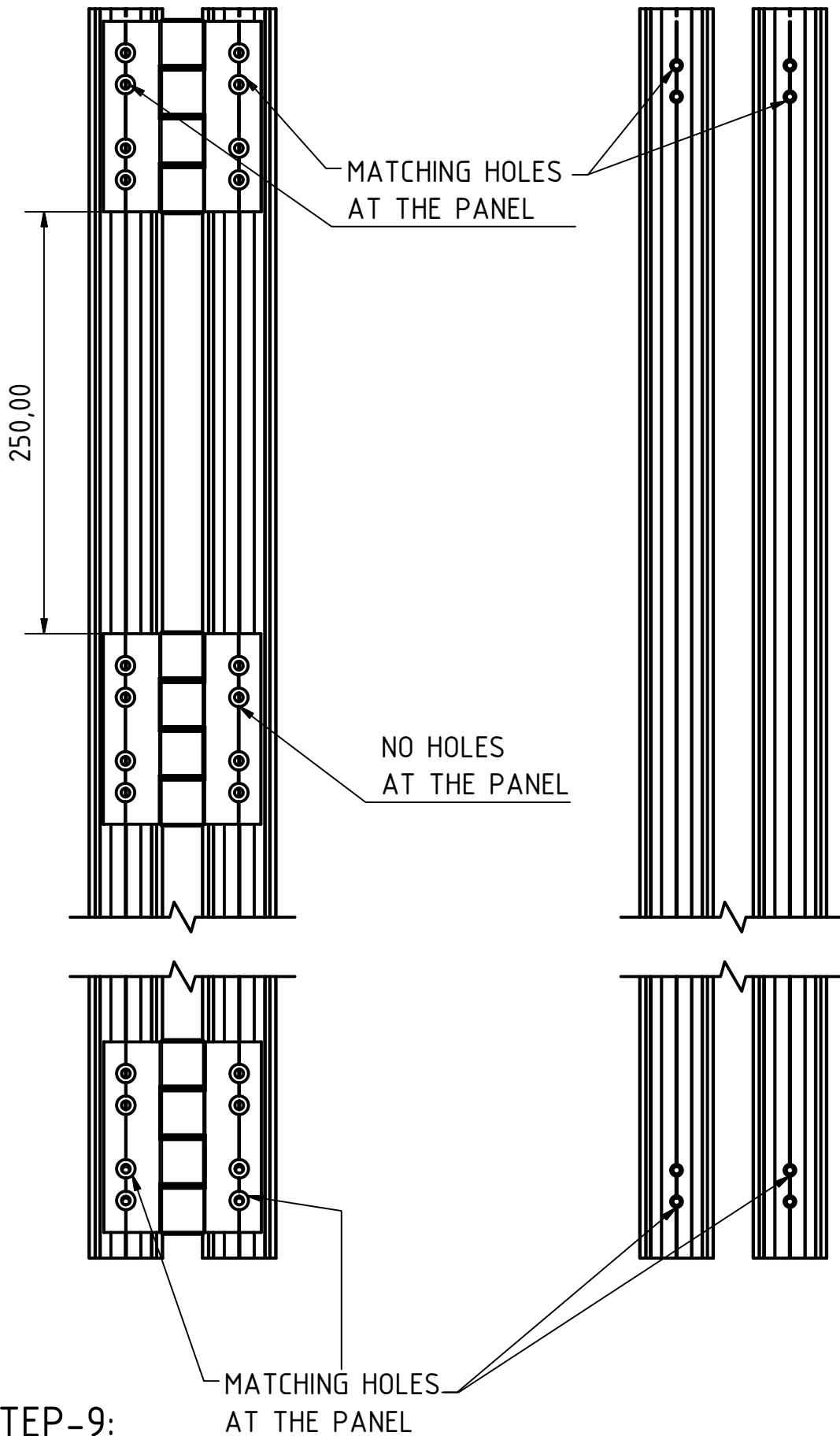

STEP-9:

Place the hinges into the panels at the specific positions.

*THE PANELS SHOULD NOT HAVE RUBBER SEALINGS IN THEM*

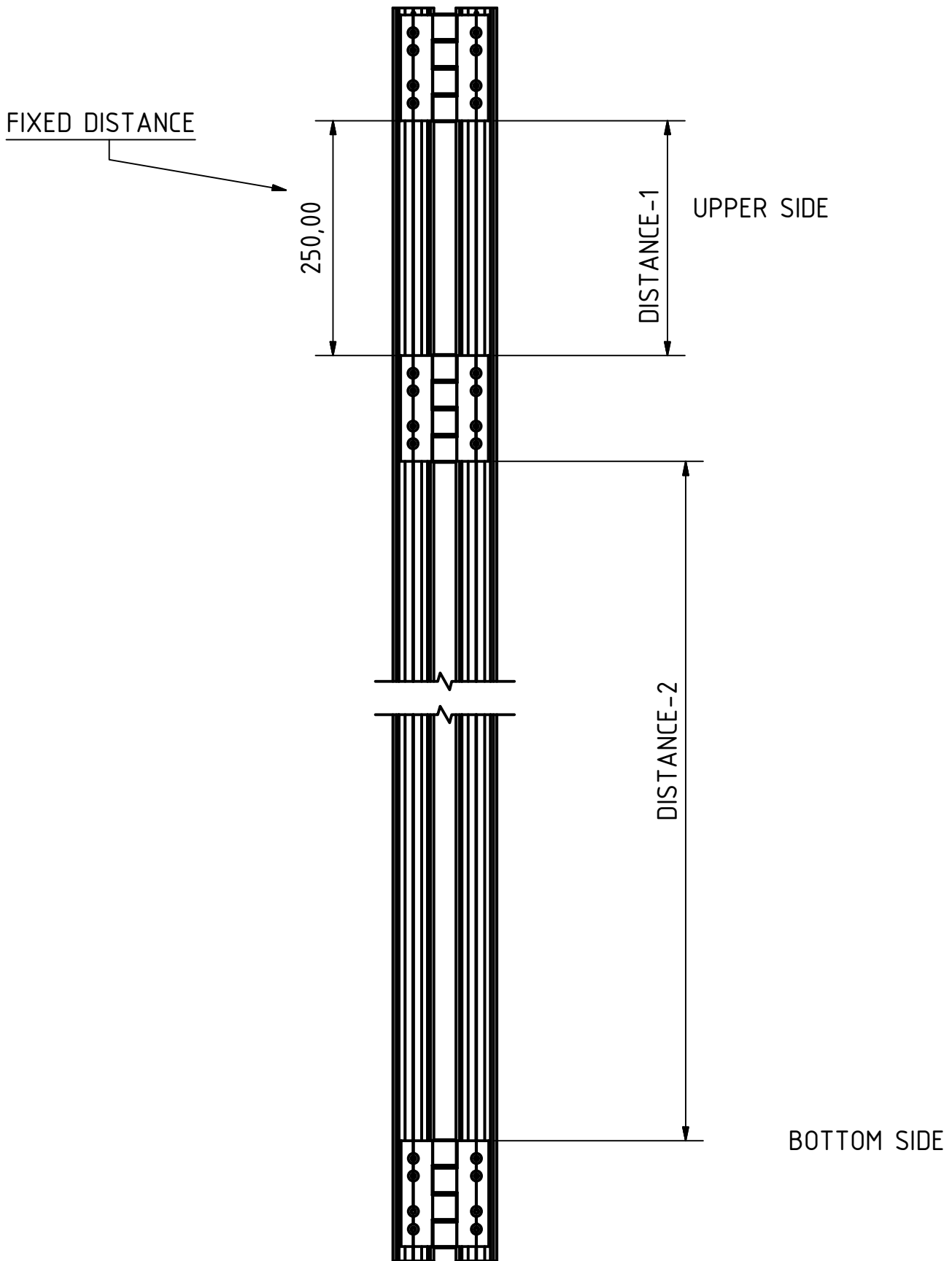

## STEP-10:

Measure the distances between the hinges .  
 The rubber sealing must be cutted at this leght  
 in order to assembly it into the panels.



RUBBER SEALING

PANEL

### STEP-11:

Remove the hinges and insert at the panels the rubber seaing pieces that had been cutted at the suitable lenghts.

THEN ASSEMBLY THE HINGES INTO THE PANELS.

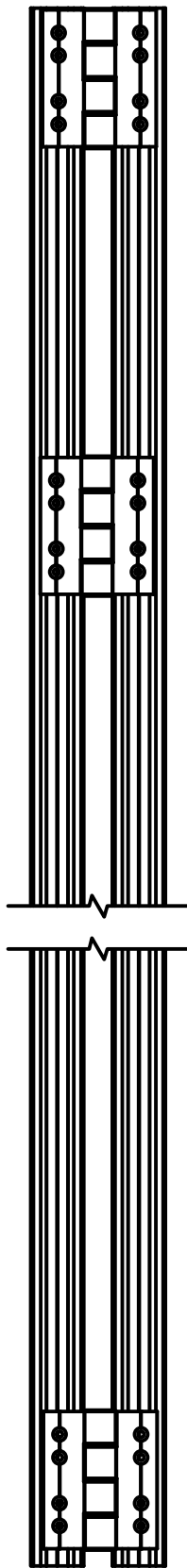

STEP-12:  
TWO (2) PANELS WITH HINGES AND RUBBER SEALINGS

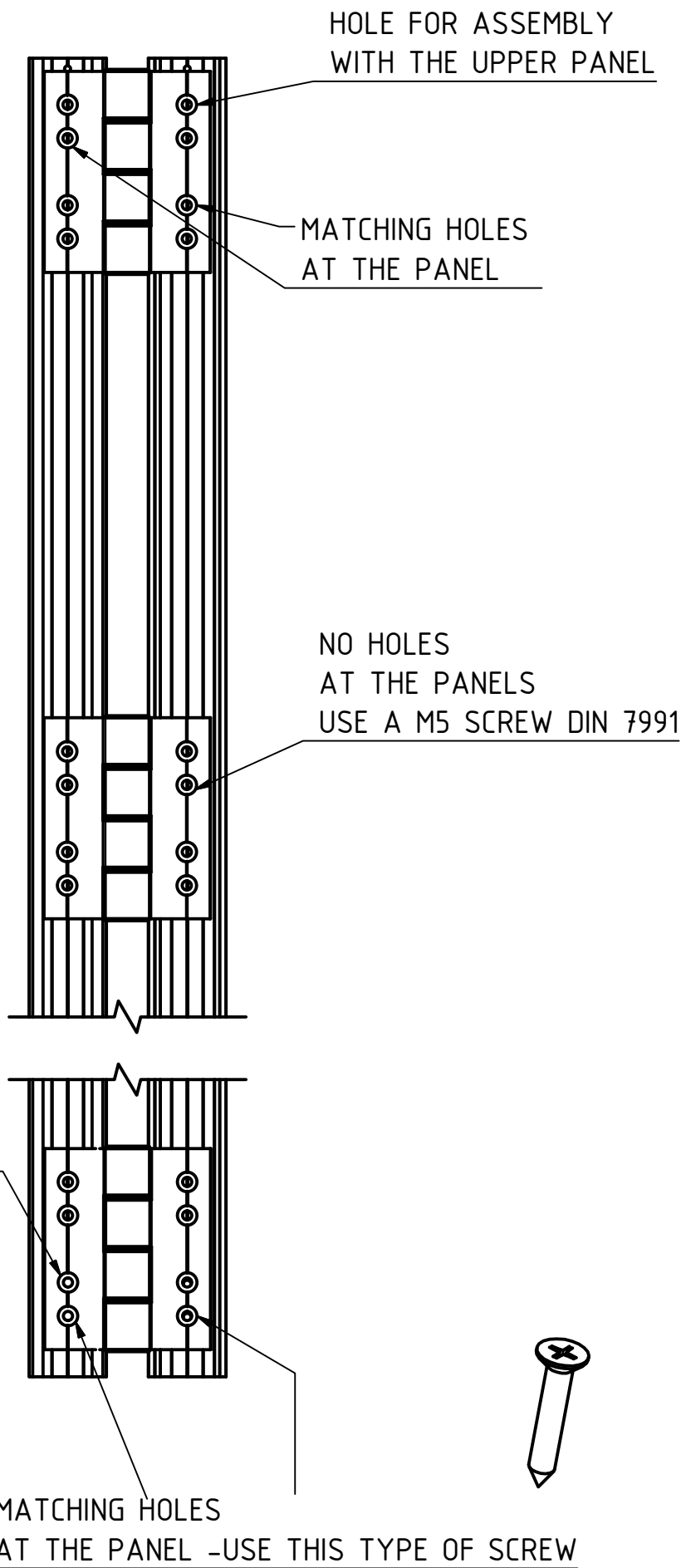

**STEP-13:**  
Assembly of the hinges at the panels.

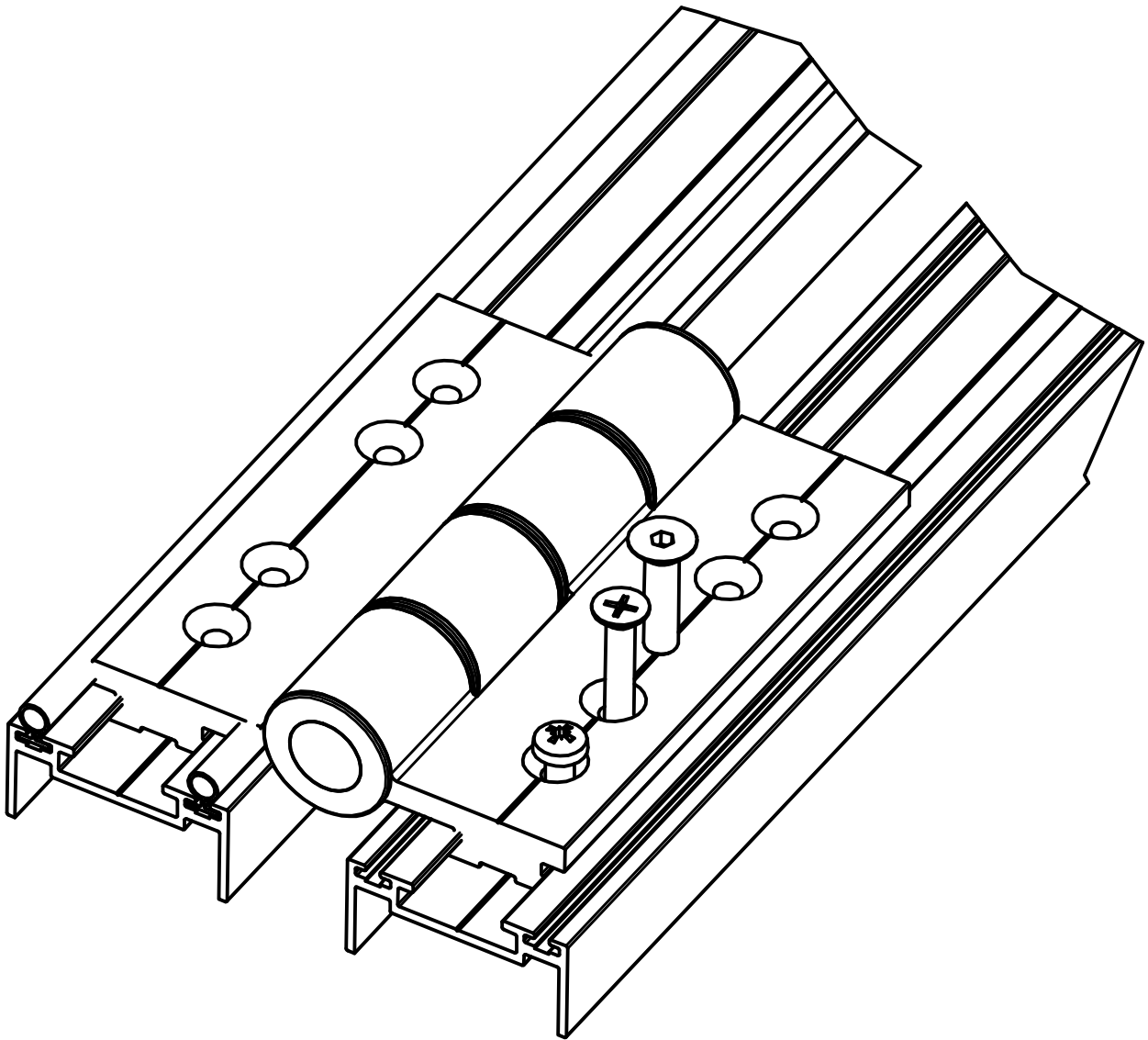

STEP-14:  
ASSEMBLY OF THE HINGES AT THE PANELS  
Screw placement and assembly



HINGES FIXED AT THE PANEL  
WITH THE SCREWS

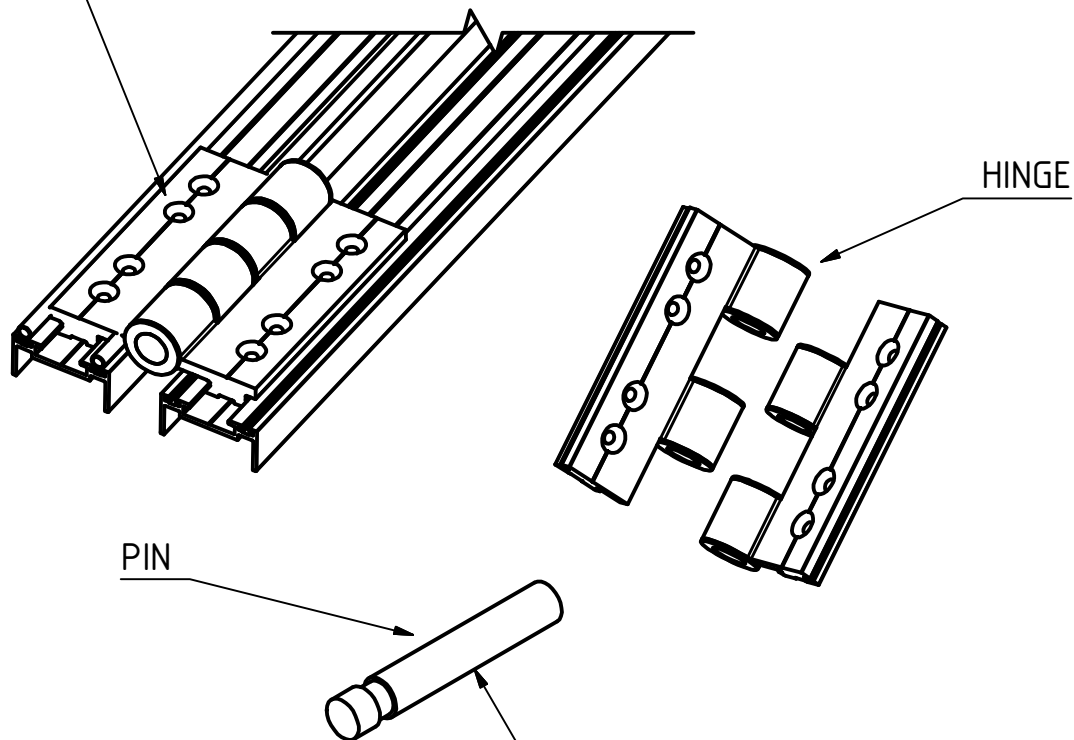

WITH THE HINGES FIXED AT THE PANELS  
(WITH THE SCREWS) REMOVE THE HINGE PIN

STEP-15:  
Disassembly the hinges.

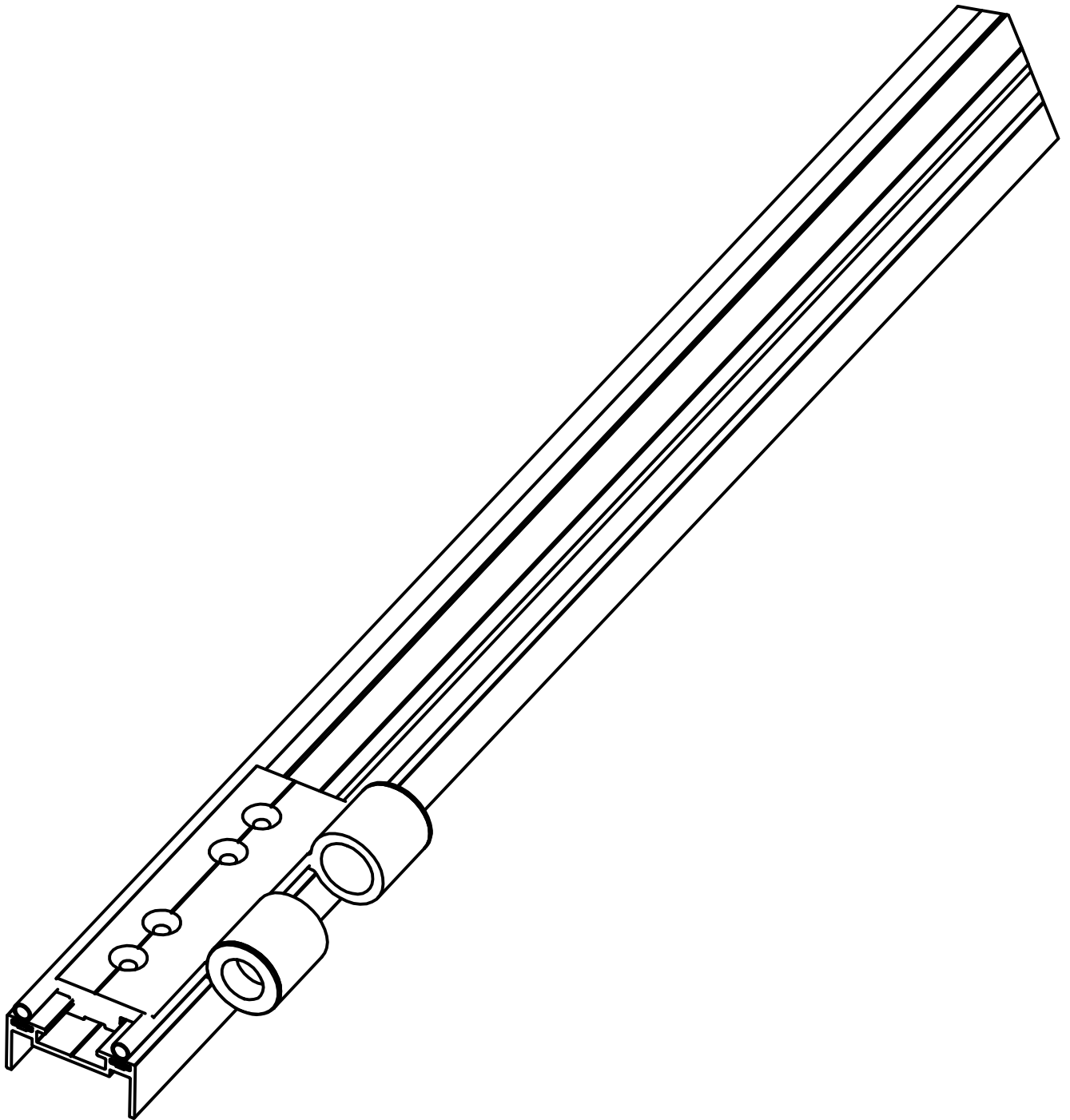

STEP-16:  
Side panel with disassembled hinges.

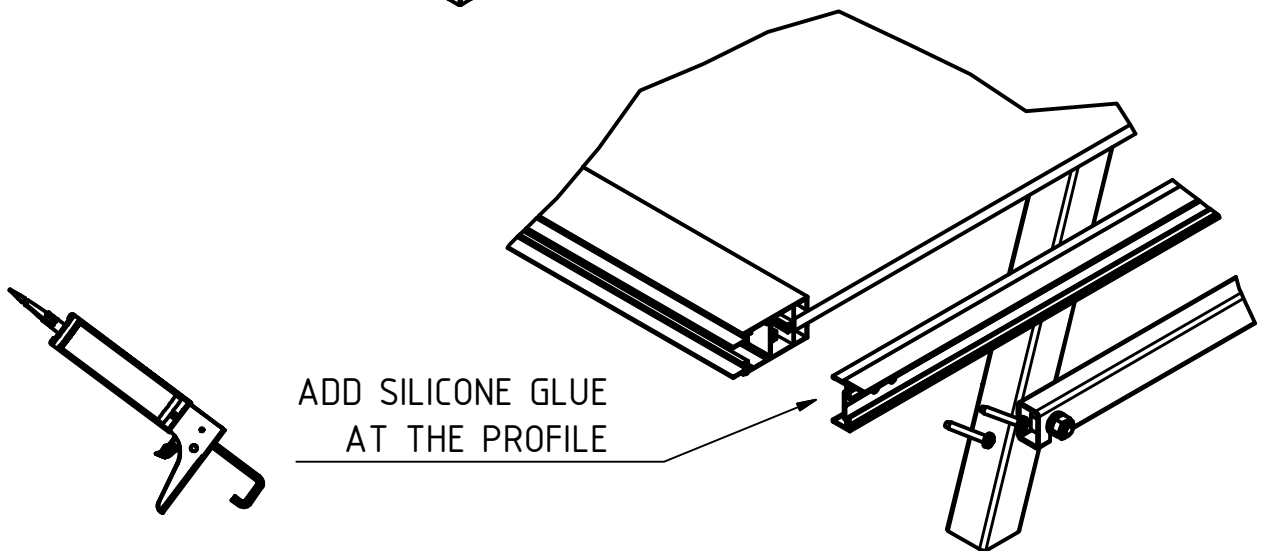
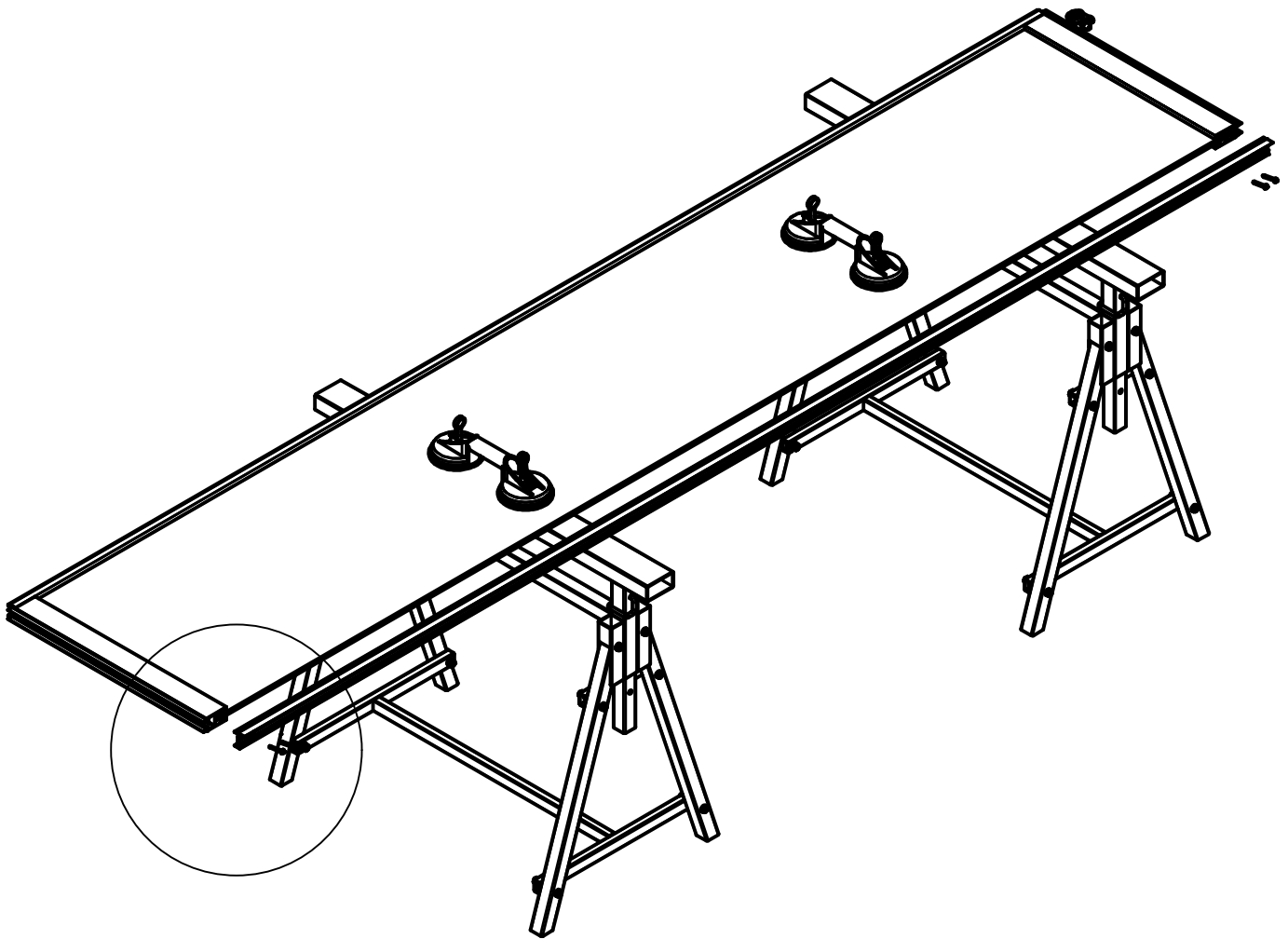

ADD SILICONE GLUE  
AT THE PROFILE

**STEP-17:**

Assembly the side panel (with DISASSEMBLED hinges) with the glass and the other panels.

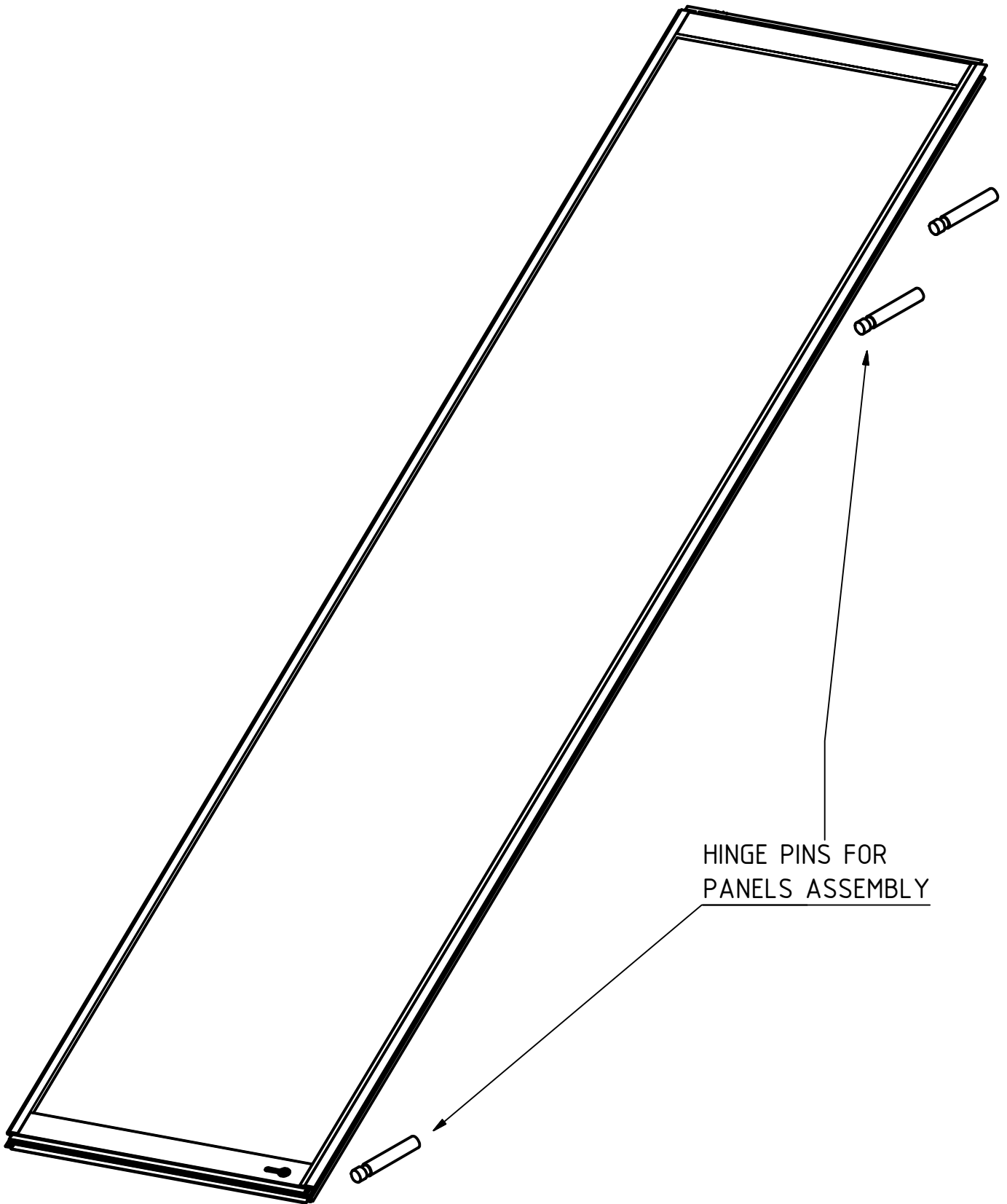

HINGE PINS FOR  
PANELS ASSEMBLY

STEP-18:

Panel is ready (WITH DISASSEMBLED HINGES)

Connection of the panels is made at the construction assembly with the hinge pins that had been removed.

  
INNOVATIVE GLASS SYSTEMS

---

[www.ialonet.gr](http://www.ialonet.gr) | [info@ialonet.gr](mailto:info@ialonet.gr)

